

## Industrial air extractor

### DESCRIPTION

- This unit consists of an electric motor and an industrial helicoidal fan with a flow rate adjusting valve. The unit comes complete with instrumentation.
- According to the CEI 1010 international convention, connections of the motor's terminal, the speed and torque sensors, are made with female connectors on doubly insulated sockets.



### SUGGESTED APPLICATIONS

- Install the air extractor and collect data during its operation
- Measure electrical power consumed and volume of air extracted
- Make the measurements to justify the adjustment of one of the components

## PRINCIPLE SCHEME

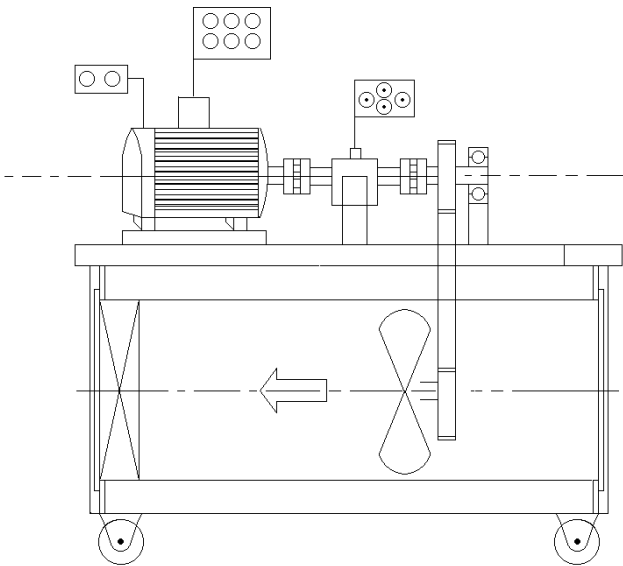

## UTILITIES

Electricity: 400 V – three-phase – 50 Hz – 6 A

## TECHNICAL CHARACTERISTICS

- **Asynchronous motor**
  - 230/400 V – three-phase - 4 poles – B3 tab
  - 1.5 kw at 1500 rpm
  - Equipped with an impulse transmitter (10 V/1000 rpm)
- **Rotative torsionmeter**
  - Rated load torque: 50 Nm
  - Maximal speed: 1500 rpm
  - Precision range: 0.1% of the rated load torque
  - Sensitivity: 2 mV/V
  - Maximal torque without damage: 130% of the rated load torque (65 Nm)
- **Fan**
  - Helicoidal type – long collar of painted steel (Ø500 mm)
  - Helix in injected aluminium – 10 blades
  - Transmission by V-belt
  - Splash guard and well for transmission
  - Shield grid at the inlet
- **Anti-vibration block**
  - Flexible collar at the blowing
  - Manual adjusting valve of the flow rate
  - Straight length Ø500 mm at the blowing
- **Two indicators for the torque and the rotations speed**
- **Motor's wiring, sensors outlets, indicators inlets on double bush, insulation, connection by female connectors.**
- **Frame in anodised aluminium section with auto-directional little wheels with brakes**
- **Electric switch box with differential breaker, isolating switch, contactor for the motor's control**