

Refrigeration cycle demonstration unit with air or water



Photo non contractuelle

The bench is delivered complete with instrumentation, technical manual and practical work.

Designing, manufacturing and industrial standards.

This unit can be used at different levels and in different fields of study.

The use of the refrigerated fluid R134a is conform to new regulations.

This bench has de the same functionalities as the CRD 400 with the possibility to operate with a condenser with water or air.

Teaching applications

- Study of the basic concepts in a refrigeration unit which utilizes R 134a refrigerant
- Study of the important phases of refrigerated cycle with compression - condensation – evaporation (water/air-water/water).
- Analysis of the theoretical refrigeration cycle.
- Analysis of the real refrigeration cycle
 - Determination of loss of charge
 - Determination of overheating
 - Determination of under cooling
 - Determination of the refrigeration power through the evaporator
 - Determination of the power through the condenser
- Calculation of thermal results through a condenser and through an evaporator
- Construction of the refrigeration cycle in a state diagram.

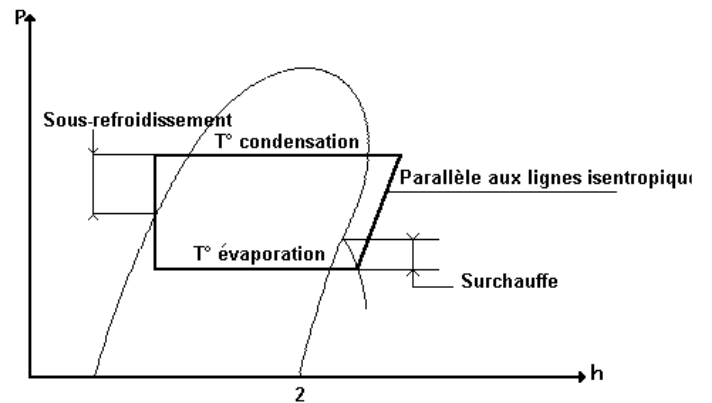

Diagram of a theoretical refrigeration cycle

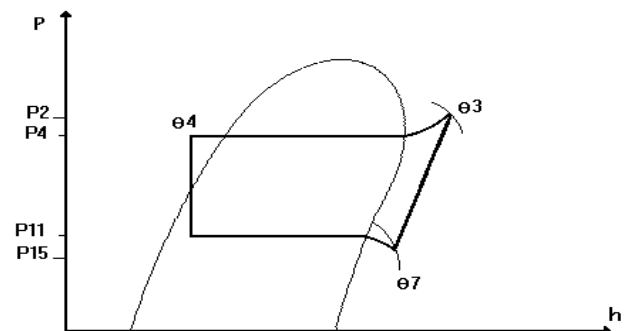
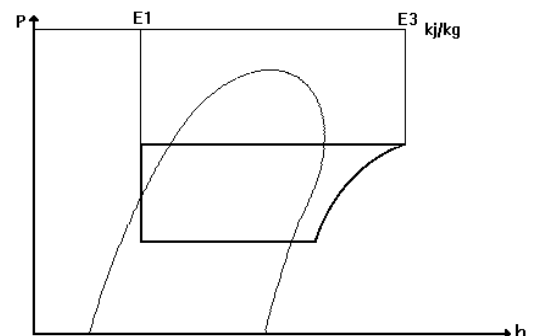
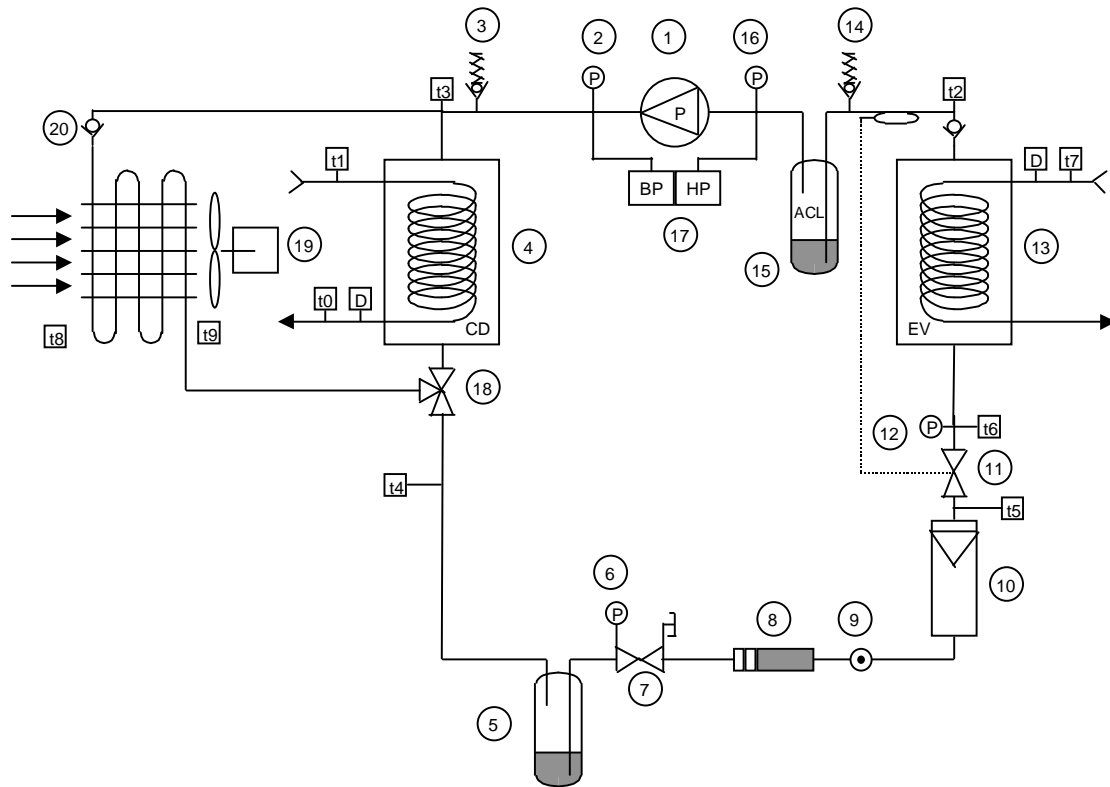

Diagram of a real refrigeration cycle



Power through the condenser

Description



1 - Sealed motocompressor

* Commercial type

* Electrical power : 1/8 CV

* Frigorific power : 402 W

- Condensation temperature : + 55°C

- Evaporation temperature : + 5°C

2 - H.P manometer compressor outlet – condenser inlet

3 - Safety valve tared at 14 bares

4 - Exchanger (condenser)

* Glass casing

* Stainless steel coil tube

* Network water entrance and evacuation

* Water flow measurement

* Temperature measurement at inlet and outlet

5 - Liquid tank

* Vertical, steel, capacity : 0.9 litre

6 - H.P. manometer liquid tank

7 - Service valve liquid point of departure

8 - Solid dehydrator

* With solid body $\varnothing \frac{1}{4}$

9 - Fluid state indicator – high pressure liquid

Rotameter

- Magnetic transmission

- Needle display

- Stainless steel construction

11 – Thermostatic expansion valve

- With internal pressure equalization

- Calibration orifice of interchangeable flow

12 - .Low pressure manometer expansion valve outlet – evaporator inlet

13 – Exchanger (evaporator)

- Glass casing

- Stainless steel coil tube

- Network water entrance and evacuation

- Water flow measurement

- Measurement of the inlet and outlet temperature

14 – SCHRADER micro valve

15 – Shock proof liquid bottle

16 – Low pressure manometer evaporator exit – compressor aspiration

17 – Safety high pressure/low pressure with manual winding

Voltmeter

Ammeter

2A Circuit breaker

18 – Diversion valve

19 – Air exchanger (condenser)

20 – Anti return valve

CRD 500

Specifications

The refrigeration cycle demonstration unit, CRD 400, is a refrigeration block of one compression stage of a commercial unit. It is equipped with the industrial materials generally used in the refrigeration industry.

This unit utilizes the refrigerant R 134, which is now the preferred refrigerant .

Optional extra

This unit can be computerized

Dimensions

Length	800 mm
Width	560 mm
Height	620 mm
Weight	50 kg

Utilities

Electricity : 230 VAC Mono 1.1 A
Other voltges can be provided on request
Water : 3 L/min (network)

Shipping specifications

Packing case size :

Length	900 mm
Width	690 mm
height	790 mm
Weight	85 kg