

Offset internal combustion engines test unit

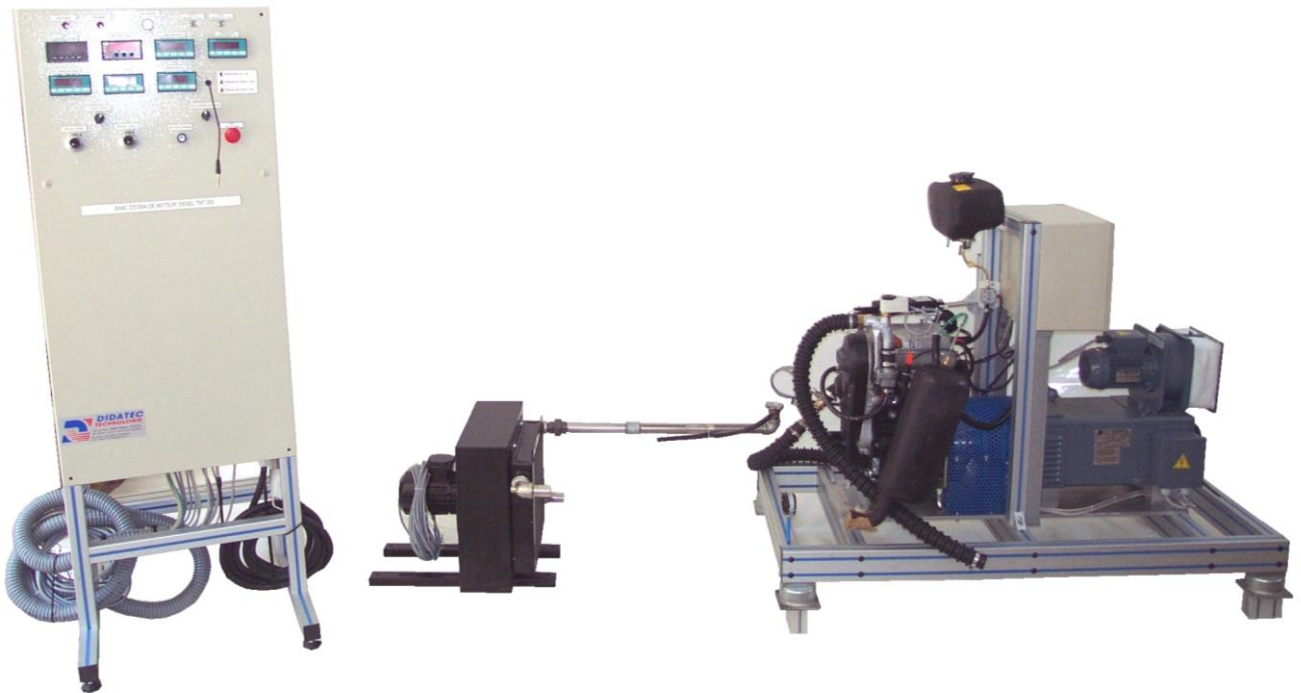

- The offset internal combustion engines unit is delivered complete with instrumentation, technical documentation, and instructions.
- The design, reduced weight and centring rails make this unit easy-to-use, and efficient.
- The engine and brake unit can be located in a separate closed room. This room will need an exhaust fan, a means of obtaining fresh air, and an duct for connecting the control panel (located in an adjacent room)
- Designed and manufactured to industrial standards.

Suggested applications

- Basic mechanics concepts: work, energy, power
- Diesel and controlled ignition engine
- Procedure for starting an internal combustion engine and safety requirements
- 2-stroke/4-stroke engine
- Determination of torque and power as a function of engine speed
- Measurement of the flow rate of fluids (liquid or gas)
- Determination of the torque and power at constant speed, with changing loads.
- Measurement of the volumetric and global efficiency of the engine
- Determination of the quantity of heat dispersed by the burning gases (option)
- Kinematics and dynamics of the engine
- Determination of the characteristics of the cooling system of an internal combustion engine

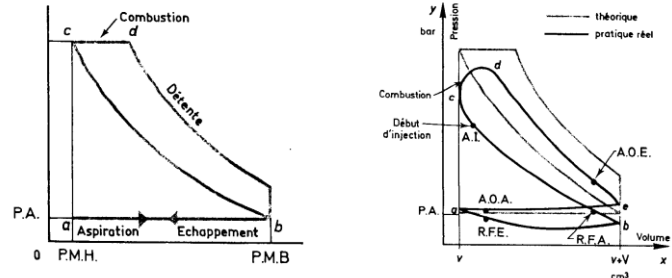

Practical diesel cycle

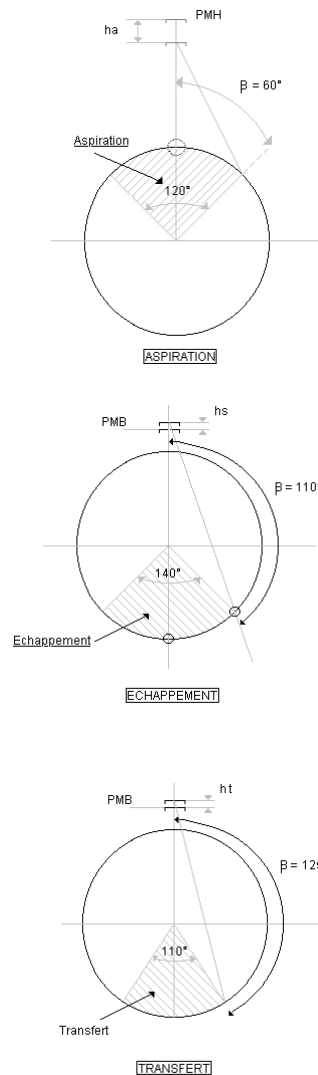

Description

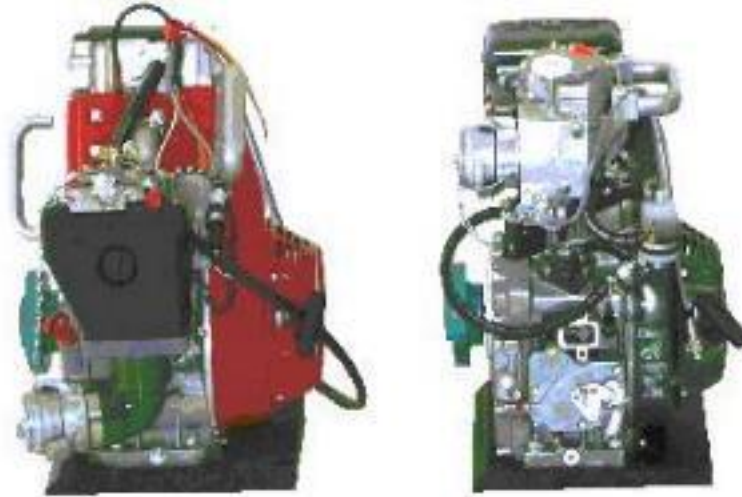

Instruments

The engines are equipped with the following analog sensors: exhaust temperature, torque and angular speed, air and gasoline flow rate, temperature and flow rate of cooling water
The signals from these sensors are shown on digital displays

Frame

Engine – Brake:
Aluminum extruded section
Set on silent blocks

Instruments:
Aluminum extruded section
Set on self-directional little wheels with brake

Other element

Electric jacks for the control of the accelerator

Engines, liquid cooling

Four stroke petrol:
Controlled ignition
twin-cylinder – 611 cc
12 kW at 3600 r.p.m.
Four stroke diesel:
Compression ignition
Twin-cylinder – 611 cc
11.8 kW at 3600 r.p.m.

Mounted on centering plates
Quick installation and coupling
Equipped with handles for shipping
Exhaust temperature sensor

Brake

CC motor - 13.8 kW
Four sphere changer
Thermal engine ignition by pushrod
Regulation of torque or speed
Load adjusted by potentiometer
Safety shields

Specifications

The unit is complete, the only additional requirement being an electrical source and exhaust gas evacuation.

Engines are easily installed on the centering rails and coupled with the cc engine thanks to a quick system. For each engine, the torque values, the rotation speed, the temperatures of exhaust and cooling water, and the flow rates of water, air and gasoline can be read directly.

The speed or the torque can be controlled and adjusted by activating the 10-revolution potentiometer.

All the connections are quick: intake air, exhaust gas, gasoline, exhaust temperature sensor, engine stop on console and mechanical coupling with brake.

Options

This unit can be computerized. It can be equipped either with one engine or two engines.

Dimensions

Length:	1 200 mm
Width:	700 mm
Height:	2 000 mm
Weight:	250 kg

Utilities

Electricity : 400 V THREE PHASE
Other voltages can be supplied on request

Shipping

Dimensions of the package :	
Length:	1 330 mm
Width:	920 mm
Height:	2 260 mm
Total weight:	350 kg