

MULTIPLE EVAPORATOR REFRIGERATION



Experimental capabilities

- Identification of the components of a refrigeration system with two cold chambers
- Commissioning and verification of operation
- Study of the basic concept of a refrigeration system with double evaporation.
- Study of the thermodynamic cycle on enthalpy diagram.
- Calculation of refrigerating capacities to the condensers and evaporators.
- Overall performance of the unit.

Operating principle

Multiple evaporation cooling unit comes complete with technical manual and practical work. It is suitable for different levels and fields of studies. Design, manufacturing and industrial equipments. The refrigerant meets the new standards of refrigerants. The robust design of this device makes it suitable for use in schools.

The equipment is set up on an anodized aluminium frame on casters wheels. This gives it great strength and a flexibility of integration into your premises. The manufacturing of this equipment meets European machine directive

Illustrations

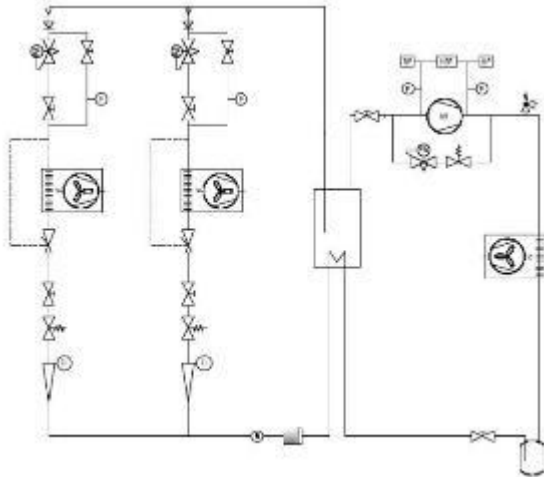

Screwed frame made of aluminum profiles

The structure made of anodized aluminum profile with four castor wheels with brake

Electrical cabinet of the installation:

The machine includes an electrical cabinet which complies with european standards. It contains at least :

- A main power switch
- A 30mA differential circuit breaker
- The relay circuitry and the necessary circuit breakers
- The pushbuttons and the indicators
- An emergency stop button
- An electronic controller of temperature with management of the operating phases per cold room

Technical details

1. Hermetic compressor
Cooling capacity: around 1400 W
Evaporation temperature -20°C
Ambient temperature +32°C
2. Air condenser
3. Receiver
Capacity : around 2.35 dm³
service valve
4. Dehydrator filter
5. Sight glass
6. Bottle exchanger between the high-pressure liquid and low-pressure steam with injection
7. solenoid valve (x2)
8. Thermostatic expansion valve with internal equalization (x2)
9. Air evaporator with forced convection (x2)
Copper tube - aluminum fins
Cooling capacity : around 660 W
10. Constant pressure valve at the outlet of each evaporator (2)
11. Check valves at the outlet of each evaporator
12. Manual valve bypass of each constant pressure valve
13. Low pressure manometers (1 for each evaporator and at the compressor suction)
14. Low pressure switch
15. Low pressure and high pressure switch
16. High pressure switch
17. High pressure manometer at the compressor outlet
18. Cold room divided into two sections with a door for each section. Each section is around 0.45m³. The walls of the cold rooms are made of 60mm thick insulation material.
19. The bench is provided with a portable thermometer equipped with two wired thermocouple probes and contact probe

Services required

- Electrical supply : 230 Vac – 50 Hz – 10 A
- Electrical network : 1 phase(s) + Neutral + Earth.
- Dimensions: (LxWxH mm): 2420 x 850 x 2150
- weight (Kg): 220

Note : if the equipment installation is operated by our staff, all supplies and exhaust connections required must stand at less than 2m from the machine

Documentation

- User's manual
- Lab exercises
- Pedagogical manual
- Technical documentation of the components
- Electrical diagram
- Fluidic diagram
- Enthalpic diagram
- Certificate of conformity CE