

HEAT PUMP WATER-WATER



Experimental capabilities

- Identification of the components of a water/water heat pump installation
- Visualization of the implementation of the system
- Visualization of the transformation of the refrigerant through glass grilles (evaporation and condensation)
- Power on, use and settings
- Measurement of various operating parameters (electric consumption, temperature of refrigerants and of water, pressures)
- Energy efficiency analysis of the system and drawing of the refrigerating cycle enthalpy diagram
-

Operating principle

The CRD400 bench allows the study of refrigerating cycle.

The bench is made of standard elements of a refrigerating circuit. The compressor will first elevate the pressure and the gas temperature (R134a). The water condenser will then transform this high pressure gas into high pressure liquid. The students visualize the transformation because the refrigerant condenses between the glass grille and the cooling coil

The high pressure liquid will then be stored in a bottle and then be sent towards the pressure reducers. This one will change the state of the fluid, it will go from a high pressure liquid to a low pressure liquid. This low pressure liquid is now in the evaporator and will draw its energy on the water coil (and thus cooling it). The students visualize the transformation because the refrigerant evaporates between the glass grille and the cooling coil. At the outlet of the evaporator, the fluid is in the form of low pressure steam, it goes through a suction line accumulator and will be compressed once again by the compressor.

The robust design of this equipment makes it perfectly suited for use in schools.

Its anodized aluminum structure on wheels makes it extremely robust as well as a great flexibility of integration into your premises. The manufacturing of this equipment meets the European machine directive

Illustrations

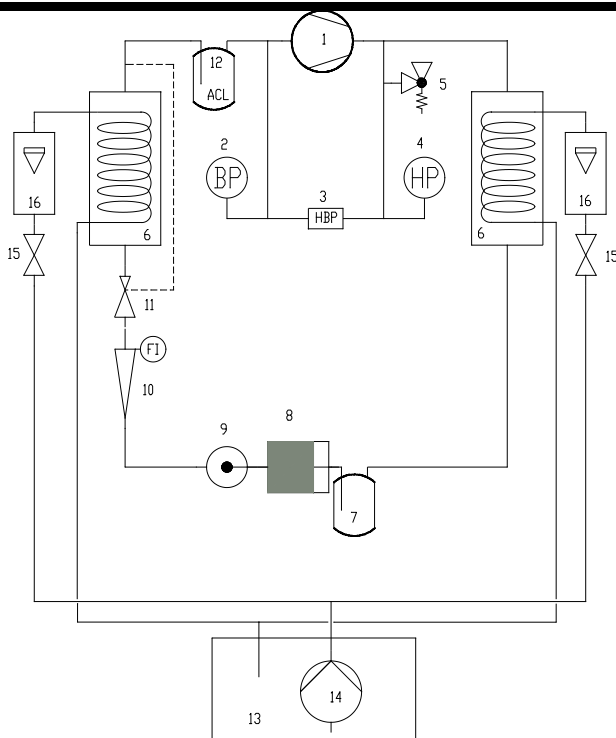

This unit is set up on a frame made of aluminum profile with 4 wheels. It includes an electrical cabinet with main switch and differential circuit breaker.

1. Hermetic piston compressor 408W for a plan 7.2 °C / 55 °C
2. Low pressure manometer R134a with dual scale temperature / pressure
3. HP and LP safety pressure switch
4. High pressure manometer R134a with dual scale temperature / pressure
5. Safety valve set to 16 bars
6. Exchangers (X2):
 - Resistant grille glass (pressure and temperature)
 - Copper coil
 - Volume of the exchanger: 1.19L
 - Fluid circulation between the grille and the coil
 - Rear lighting by neon (improves the visualization)

Technical details

7. Liquid tank steel 0.7L volume with service valve
8. Dehydrator filter
9. Fluid state LED
10. R134a refrigerant flowmeter with needle with magnetic transmission
11. Thermostatic expansion valve with internal pressure equalization
12. Suction line accumulator in steel volume 0.3L
13. Cooling water tank with lid:
 - Material: white polyethylene
 - Volume: 75L
 - Drain valve in the lower part
14. Submersible pump, Body, suction strainer and turbine in techno polymer
 - Power: 0.37KW maximum flow rate: 6m3/h
 - Maximum HMT: 9mCE
15. Water flow rate control valve
16. Water float flowmeter (X2)
 - Integrated instrumentation:
 - Low pressure manometer: -1 to 10bars
 - High pressure manometer: -1 to 30bars
 - Fluid flowmeter R134a: 40 to 250mL /min
 - Water flowmeter (X2): 0.2 1.5 L/min
 - Thermocouple temperature probes T (X8): -20 to +100°C
 - Compressor power wattmeter: 0 to 1150W

The temperatures and the power are displayed on a 7" touch screen :

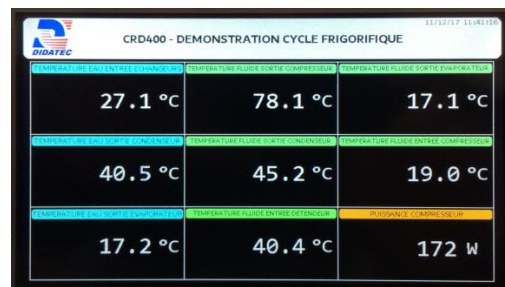

CRD400



Services required

- Electrical supply: 230 Vac – 50 Hz – 10 A
- Electrical network: 1 live(s) + Neutral + Earth.
- Water tank volume: 70L
- Dimensions: (LxWxH mm): 1000 x 800 x 1510
- weight (Kg): 110

Note : if the equipment installation is operated by our staff, all supplies and exhaust connections required must stand at less than 2m from the machine

Documentation

- User's manual
- Pedagogical manual
- Technical documentation of the components
- Wiring diagram
- Fluidic diagram (PID)
- Lab exercises
- Certificate of conformity CE

Options

- Data acquisition system and real time drawing of the enthalpic diagram
3 temperature sensors and 2 pressure sensors (HP and LP)
- Full Data acquisition system and real time drawing of the enthalpic diagram
- 8 temperature sensors, 2 pressure sensors (HP and LP), 3 flow sensors (water and frigorific fluid)

- Ref : CRD401

- Ref : CRD402

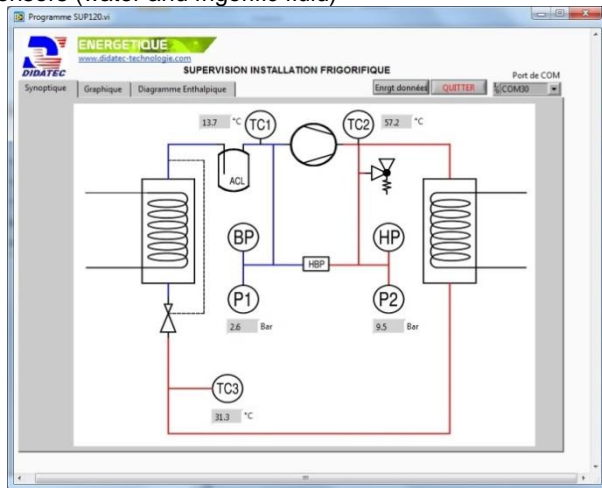

Schematic diagram with real time display

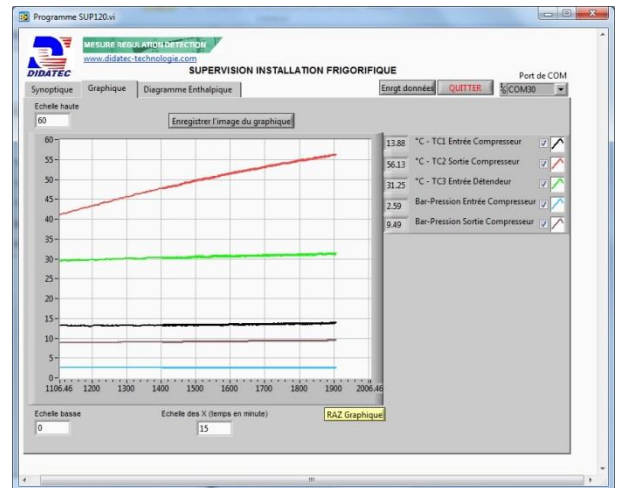

Real time trend

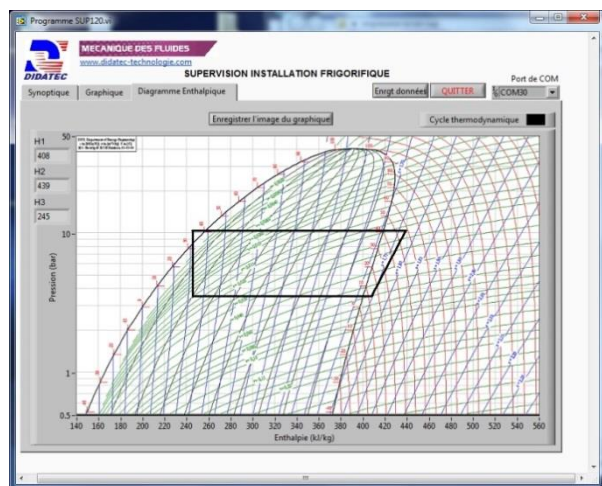

Real time enthalpic diagram

DIDATEC– Zone d'activité du parc – 42490 FRAISSES- FRANCE
Tél. +33(0)4.77.10.10.10 – Fax+33(0)4.77.61.56.49 – www.didatec-technologie.com
email : service_commercial@didatec-technologie.com

Reproduction interdite / copy prohibited– Copyright DIDATEC déc.-17- page 3

Dans le cadre de l'amélioration permanente de nos produits, ce descriptif technique est susceptible d'être modifié sans préavis
As part of the continuous improvement of our products, this technical specification may be modified without previous notifying

Illustrations non contractuelles / Illustrations not contractual

version : FT-CRD400-STD-C