

EXPANSION VALVE AND CAPILLARY TUBES TEST BENCH

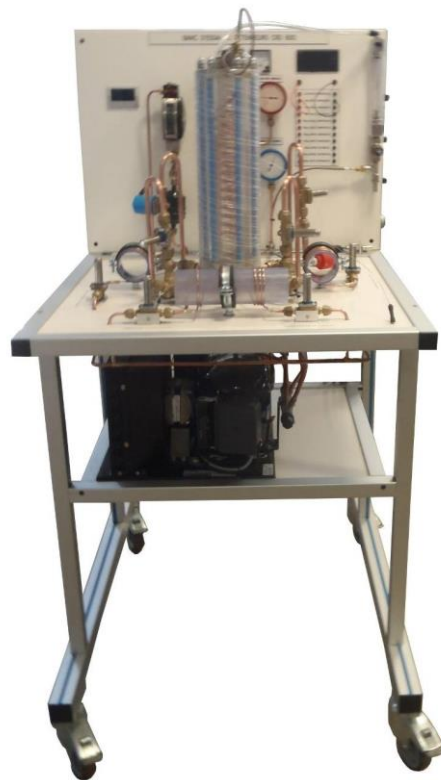

Experimental capabilities

- Identification and use of different type of expansion systems :
 - internal equalisation thermostatic
 - external equalisation thermostatic
 - automatic expansion valve
 - Capillary tubes :2 different lengths & 2 different diameters
 - electronic expansion valve
- Study of the influence of the diameter and the length on capillary tubes
- Adjustment of the overheat on the thermostatic expansion valves
- Parameterizing of the electronic expansion valve
- Study of a refrigeration circuit and drawing of the enthalpic cycle

Operating principle

The unit is delivered complete with instrumentation as well as with technical and instruction manuals. The components are of industrial quality. The operation of the valves is similar to those found in a commercial installation. A variety of parameters may be measured.

The robust design of this device makes it suitable for use in schools. The equipment is set up on an Anodized aluminium frame on casters wheels. This gives it great strength and a flexibility of integration into your premises. The manufacture of this equipment complies with the European standard for machinery manufacturing.

This equipment can be used alone or with other compatible equipment from our range (see last section of this document).

Illustrations

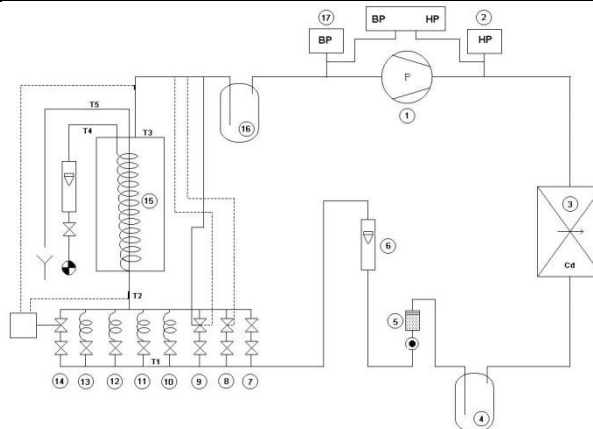

Technical details

1. Reciprocating compressor R134a
Refrigeration power around 500 W
2. High pressure gauge and pressure switch
3. Condenser – with air blower
4. Receiver
5. Filter drier and moisture indicator
6. R134a flowmeter, magnetic transmission, needle display, stainless steel body
7. Automatic expansion valve
8. Internal equalisation expansion valve
9. Internal equalisation expansion valve
10. Capillary tube diameter1, Length1
11. Capillary tube diameter1, Length2
12. Capillary tube diameter2, Length1
13. Capillary tube diameter2, Length2
14. Electronic expansion valve
15. Evaporator: glass shell to view the evaporation of R134a, copper coil (water inside), water inlet and outlet, measurement of the water flowrate
16. Suction line accumulator
17. low pressure gauge and pressure switch
18. Integrated Instrumentation:
 - Gauge low pressure: -1 to 10bar
 - Gauge high pressure: -1 to 30bars
 - Fluid flowmeter R134a: 40 to 250mL/min
 - Water flowmeter: 0.2 to 1.5 L/min
 - Thermocouple temperature probes T (X) on the water and the refrigerant : -20 to +100°C

Services required

- Electrical supply : 230 Vac – 50 Hz – 6 A
- Electrical network : 1 phase(s) + Neutral + Earth.
- Water supply : 1.5 L/min – 1 bars
- Water drain : on the floor
- Dimensions: (LxWxH mm): 1000 x 800 x 1600
- weight (Kg): 75

Documentation

- User's manual
- Pedagogical manual
- Technical documentation of the components
- Lab exercises
- Certificate of conformity CE

Note : if the equipment installation is operated by our staff, all supplies and exhaust connections required must stand at less than 2m from the machine

CRD600



Options

- Data acquisition system and real time drawing of the enthalpic diagram : 3 temperature sensors and 2 pressure sensors (HP and LP)
- Full Data acquisition system and real time drawing of the enthalpic diagram : 8 temperature sensors, 2 pressure sensors (HP and LP), 2 flow sensors (water and frigorific fluid)
- Ref : CRD601
- Ref : CRD602

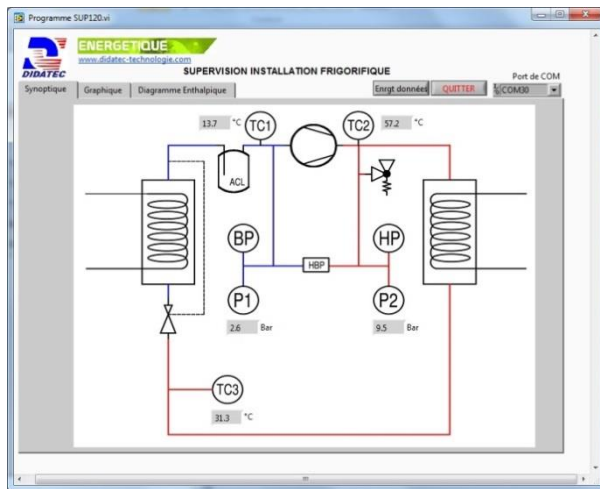

Schematic diagram with real time display

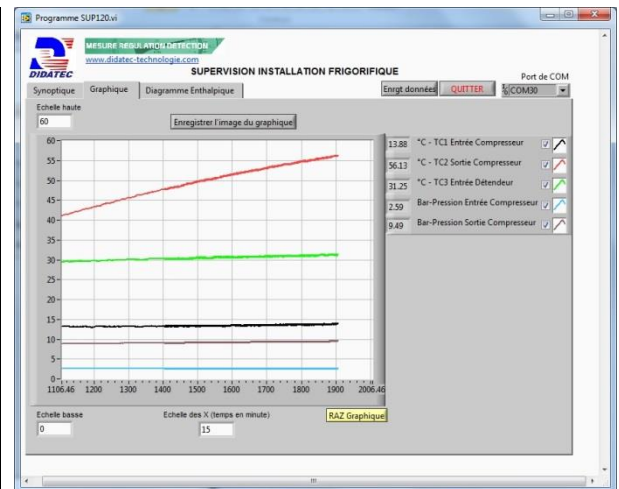

Real time trend



Real time enthalpic diagram