

HYDROSTATIC PRESSURE IN LIQUIDS

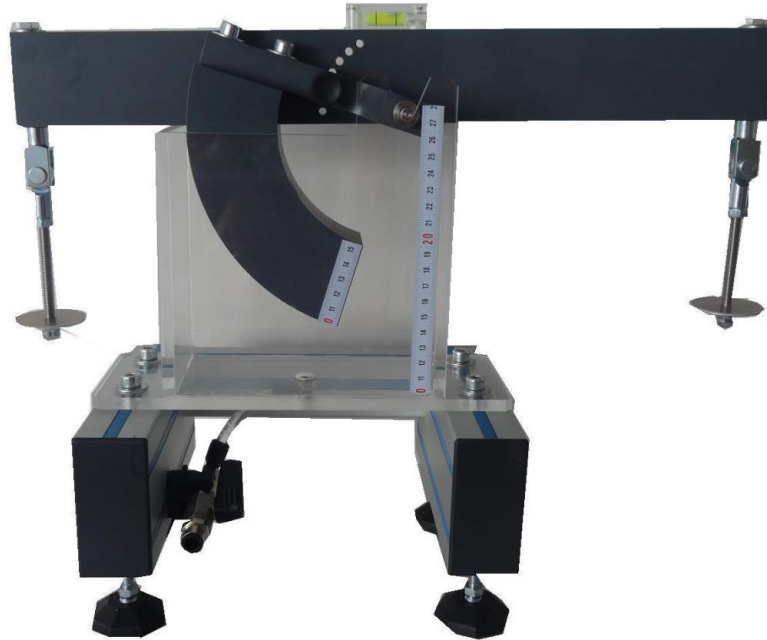

Experimental capabilities

- **Measurement of the thrust of a fluid on a flat surface**
- **Tests on vertical or inclined surfaces**
- **Height of variable liquid**
- **Determine the center of thrust of the surface subjected to the pressure forces**

Operating principle

The bench PBP 150 allows you to make typical tests of the study of hydrostatic pressure in liquids at rest. It allows to view the effects of the hydrostatic pressure of the water with different water levels and inclination angles. The test device consists of a transparent water tank with a graduated scale for the determination of volume. It is also possible to adjust the angle of the submerged form. Using different weights, we do the tare of the device by means of a lever arm, and then we determine the thrust force and also the position of the center of thrust. The robust design of this equipment makes it suitable for use in schools. Its anodized aluminum structure on wheels with brakes gives it a very robust as well as a high flexible integration into your premises. The manufacturing of this equipment meets European machine directive

Illustrations

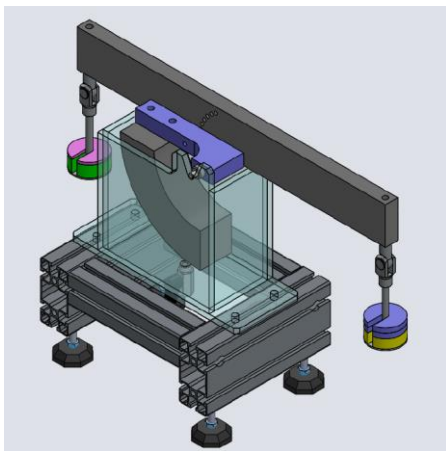

Technical details

- Two plates with weight hooks**
 - Series of masses provided
 - 2,5N, 2N, 1N, 0,5N
 - Precision shims
- Lever arm**
 - Length: 240 mm
- Water tank**
 - Transparent glass
 - Drain valve
- Glass made of transparent plastic**
 - Graduated level scale in mm
- Rotation axis**
- Variation of the angle of inclination of the submerged form**

Services required

- Tank water : 2,6L
- Dimensions: (LxWxH mm): 400 x 150 x 300
- weight (Kg): 5

Note : if the equipment installation is operated by our staff, all supplies and exhaust connections required must stand at less than 2m from the machine

Documentation

- User's manual
- Technical documentation of the components
- Lab exercises
- Certificate of conformity CE