

POSITIVE REFRIGERATION KIT



Experimental capabilities

- Identification of components of a positive refrigerating system
- Piping and wiring
- Leak testing of the cold circuit
- The refrigerating fluid load (requires tooling and fluid not supplied)
- Commissioning and setting (pressure reducer, pressure switches ...)
- Study of the basic concept of a refrigeration plant.
- The system with industrial rendering
- The kit comes with the main components attached to the support. The wiring and piping are not realized. (See photo above)

Operating principle

The positive refrigeration kit allows to train students in the realization of a positive refrigeration system. The system includes all the standard components such as compressor, condenser, expansion valve, evaporator, bottles, pressure switches.

The kit comes complete with the main components attached to the support. Students can work on identifying the components, the shaping of refrigerant piping, the wiring of the cabinet, leak testing, the refrigerant load (requires the tooling not supplied with the bench), commissioning, adjusting and verifying the proper operation.

The kit is intended to be assembled with the cold rooms type CHB100 of DIDATEC brand.

The robust design of this equipment makes it perfectly suited for use in schools.

Its structure in anodized aluminum on wheels gives it great strength as well as great flexibility of integration into your premises. The manufacturing of this equipment meets European machine directive

Illustrations

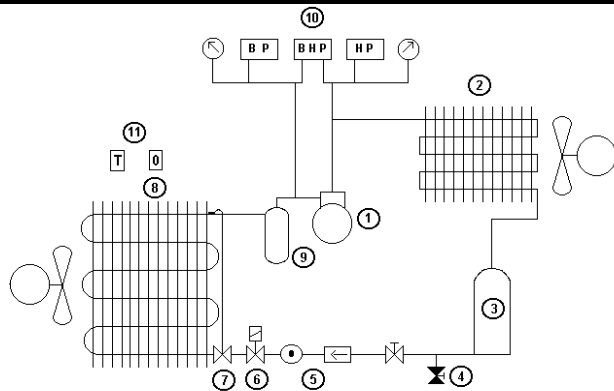

1. A hermetic compressor
Evaporation temperature 0°C
Maximum pressure: 32 bars
Power: 900W
Equipped with two service valves
2. Air condenser
forced convection
3. Liquid tank
Vertical made of steel
Volume: 1.5L
4. Refrigerant recovery valve
5. Dehydration station
Solid cartridge dehydrator Ø1/4 "
Fluid state LED Ø1/4 "
6. An electromagnetic valve
Normally closed
Straight passage Ø1/4 "
7. Thermostatic expansion valve
Internal pressure equalization with calibrated orifice
(-40°C /+ 10°C)

Technical details

8. Air evaporator
Forced convection
Evaporation temperature 0°C
Power: 650W
9. A suction line accumulator.
Vertical made of steel
Volume: 1.5L
10. Control and safety system
High pressure gauge
Low pressure gauge
High pressure switch control
Low pressure switch control
HLP combined safety pressure switch

The electrical cabinet of the system includes:

- an electrical cabinet made of steel with a 230VAC plug to connect the accessories.
- the standard safety elements (main switch, emergency stop button, GFCI, connection to earth and white light)
- a circuit breaker for each element
- the relays for the main components of the system (evaporator, electro valve, compressor, condenser, defrost heater)
- lights for each component
- a refrigeration temperature controller with 2 probes to manage all the components (defrost, ventilation...)

Characteristics of the frame:

- the frame is made of anodized aluminum screwed profiles
- it is set up on 4 wheels diameter 100mm.

CHK200



Additional material supplied

The kit is supplied with the equipment necessary for the realization of piping and electrical wiring:

- 30mL annealed copper tube 1/4 "
- 15mL annealed copper tube 3/8 "
- 30mL of insulation tube 1/4 "
- 15mL of insulation tube 3/8 "
- 100m of cable 3G0.75
- 50m of cable 4G0.75
- 100m of white wire 0.75mm²
- 100m of red wire 0.75mm²

- 100m of black wire 0.75mm²
- 100m of blue wire 0.75mm²
- 100m of black wire 1,5mm²
- 100m of blue wire 1,5mm²
- 100m of ground wire 0.75mm²
- A batch of refrigeration fittings (nuts ...)
- A batch of electrical accessories (tip ends, collars ...)

The tooling required to achieve is not included in delivery.

Services required

- Power supply: 230 Vac – 50 Hz –10A
- Power supply Type: 1 phase(s) + Neutral + Earth.
- Dimensions : (LxWxH mm): 800 x 800 x 1700
- weight (Kg): 95

Note : if the equipment installation is operated by our staff, all supplies and exhaust connections required must stand at less than 2m from the machine

Documentation

- User's manual
- Technical documentation of the components
- Lab exercises
- Wiring diagram
- Fluidic diagram
- Certificate of conformity CE

Recommended equipment

- Cold Room

- Ref : CHB 100