

STUDY OF THE SERVICING OF A REFRIGERATION UNIT



Experimental capabilities

- Identification of the components of an installation operating with R134a
- Commissioning and settings (temperature controller-expansion valve) of a refrigerating installation
- Standard operation procedure to recover and load the refrigerant (requires additional tooling OUT134)
- Setting of the control components (pressure control valve, pressure switch LP, pressure switch HLP)
- Maintenance operations on a refrigeration installation, replacement of the dehydrator, replacement of a pipe on the low pressure side (requires additional tooling OUT134)
- Draw of the refrigeration cycle on enthalpy diagram to check the operation of the installation

DIDATEC– Zone d'activité du parc – 42490 FRAISSES- FRANCE
Tél. +33(0)4.77.10.10.10 – Fax+33(0)4.77.61.56.49 – www.didatec-technologie.com
email : service_commercial@didatec-technologie.com

Reproduction interdite / copy prohibited– Copyright DIDATEC juin-16- page 1

Dans le cadre de l'amélioration permanente de nos produits, ce descriptif technique est susceptible d'être modifié sans préavis
As part of the continuous improvement of our products, this technical specification may be modified without previous notifying

Operating principle

The HFF134 bench is designed to train the learners in the handling of refrigerants. The installation is based on a refrigerating cycle operating with R134a. It comprises the main components of a positive installation, a compressor, a condenser, a receiver, a solenoid control valve, an expansion valve, an evaporator and a suction line accumulator. Service valves and fittings Schrader type allow the learners to connect a manifold for the load operations, recovery operation and verification operation.

The cold chamber is simulated by a cabinet. The cabinet door is equipped with an enthalpy diagram R134a with erasable surface (format A3). A thermostatic control box will control the operation of the solenoid valve (pump down control). Two switches located on the box are used to stop the operation of the solenoid valve and of the condenser (this facilitates adjustment of the pressure switches).

The robust design of this equipment makes it perfectly suited for use in schools. Its anodized aluminum structure on wheels makes it extremely robust as well as a great flexibility of integration into your premises. In the lower part, the bench comprises a storage area equipped with two doors with key locking (storage of tooling).

The manufacturing of this equipment meets European machine directive

This equipment can be used alone or with other compatible equipment in our range (see last section of this document).

Illustrations

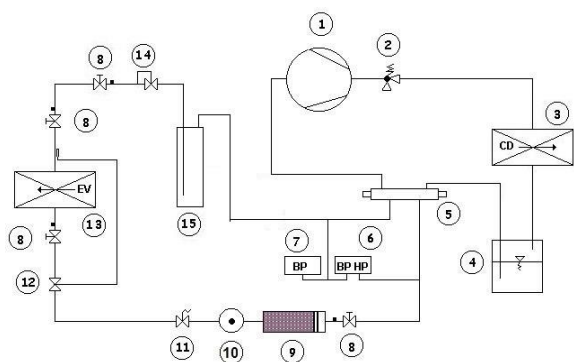

1. Hermetic compressor power 508W (0°C evaporation / condensation 32°C)
2. Safety valve
3. Forced ventilation air condenser
4. receiver made of steel volume 0.75L
5. Service valves
6. Safety pressure switch HLP
7. LP control pressure switch
8. Ball valve with connector Schrader
9. Filter + dryer 1/4"
10. sight glass
11. solenoid control valve

Technical specifications

12. expansion valve with internal equalization
13. Evaporator with forced convection power 495W at dt 7K
14. Pressure regulating valve of evaporation KVP type
15. Suction line accumulator volume 1.5L

The bench also includes:

- a power supply module with a differential circuit breaker and a 2P+ T socket for connecting the accessories (pump, recovering station ...)
- a digital thermostatic control box with probe in the chamber. The controller controls the solenoid valve (control pump down). Two switches are used to stop the operation of the condenser and the solenoid valve (adjusting pressure switches).
- a cold chamber simulated by a cabinet. The cabinet door is equipped with an enthalpy diagram R134a with erasable surface (format A3).
- a storage area in the lower part of the frame with two access doors. A key lock is used to secure the storage.

Basic tool kit included

- Wrench large format
- Wrench small format
- Flat screwdriver
- Phillips screwdriver
- Tom thumb flat screwdriver
- Phillips screwdriver tom thumb
- Flat key 10
- Flat key 11
- Measuring tape
- Refrigeration ratchet wrench

Kit of spare parts supplied

- Dehydrator
- Sight glass
- Thermostatic expansion valve with internal pressure equalization and orifice
- Magnetic solenoid valve coil
- Cleaning tissu
- Cleaning products
- Leak detector (liquid soap)
- 5 nuts 1/4"
- 2 nuts 3/8"
- 1 double nut 1/4"
- 1 nut reduced 3/8"- 1/4"
- 1 nut reduced 3/8"- 1/2"

HFF134



Services required

- Power supply: 230 Vac – 50 Hz – 10 A
- Power supply type: 1 phase(s) + Neutral + Earth.
- Dimensions: (LxWxH mm): 1160 x 640 x 1790
- weight (Kg): 150

Note : if the equipment installation is operated by our staff, all supplies and exhaust connections required must stand at less than 2m from the machine

Documentation

- User's manual
- Pedagogical manual
- Technical documentation of the components
- Lab exercises
- Certificate of conformity CE

Options

- Specific tools kit for refrigerant
- Ref : OUT 134