

NEGATIVE REFRIGERATION SYSTEM



Experimental capabilities

- Identification of components of a negative refrigerating system
- Commissioning and verification of operation
- Study of the basic concept of a refrigeration plant .
- Study of the thermodynamic cycle on enthalpic diagram.
- Study of the regulation
- The system with industrial rendering
- The kit comes assembled, loaded and functional

Operating principle

The negative refrigeration kit allows the study of a negative refrigerating system. The system includes all the standard components such as compressor, condenser, expansion valve, evaporator, bottles, pressure switches.

The kit is supplied complete, assembled and functional. Students can work on identifying the components, commissioning, adjustment and the verification of operation. They will also be able to recover the fluid and the load (requires the tooling not supplied with the bench).

The kit is intended to be assembled with the cold rooms type CHB100 of DIDATEC brand.

The robust design of this equipment makes it perfectly suited for use in schools.

Its structure in anodized aluminum on wheels gives it great strength as well as great flexibility of integration into your premises.

The manufacturing of this equipment meets European machine directive.

Illustrations

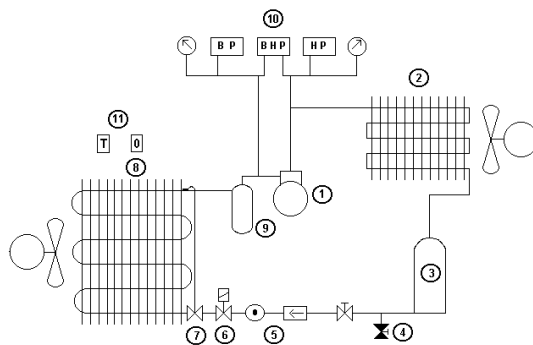

1. A hermetic compressor
Evaporation temperature -25°C
Maximum pressure: 32 bars
Power: around 700W
Equipped with two service valves
2. Air condenser
forced convection
3. Fluid reservoir
Steel vertical
Volume: 1.5L
4. Refrigerant recovery valve
5. Dehydration station
Solid cartridge dehydrator $\varnothing 1/4$ "
Fluid state LED $\varnothing 1/4$ "
6. An electromagnetic valve
Normally closed
Straight passage $\varnothing 1/4$ "

Technical details

7. Thermostatic expansion valve
Internal pressure equalization with calibrated orifice (-40°C / $+10^{\circ}\text{C}$)
8. Air evaporator
With forced convection
Evaporation temperature -25°C
Power: around 700W
Electric defrost
9. A suction line accumulator.
Steel vertical
Volume: 1.5L
10. Control and safety system
High pressure manometer -1 to 30bars
Low pressure manometer -1 to 10bars
High pressure switch control
Low pressure switch control
HBP combined safety pressure switch
Safety thermostat

The electrical side of the system includes :

- an electrical cabinet made of steel with a 230VAC plug to connect the accessories.
- the standard safety elements (main switch, emergency stop button, GFCI, connection to earth and white light)
- a circuit breaker for each element
- the relays for the main components of the system (evaporator, electro valve, compressor, condenser, defrost heater)
- lights for each component
- a refrigeration temperature controller with 2 probes to manage all the components (defrost, ventilation...)

Services required

- Power supply: 230 Vac – 50 Hz – 10 A
- Power supply Type: 1 phase(s) + Neutral + Earth.
- Dimensions: (LxWxH mm): 800 x 800 x 1700
- weight (Kg): 105

Note : if the equipment installation is operated by our staff, all supplies and exhaust connections required must stand at less than 2m from the machine

Documentation

- User's manual
- Pedagogical manual
- Technical documentation of the components
- Lab exercises
- Wiring diagram
- Fluidic diagram
- Certificate of conformity CE

Recommended equipment

- Cold room

- Ref : CHB 100